

Lecture 15 – Examples of Pushdown Automata

COSE215: Theory of Computation

Jihyeok Park



2026 Spring

A **pushdown automaton (PDA)** is a finite automaton with a **stack**.

- Acceptance by **final states**
- Acceptance by **empty stacks**

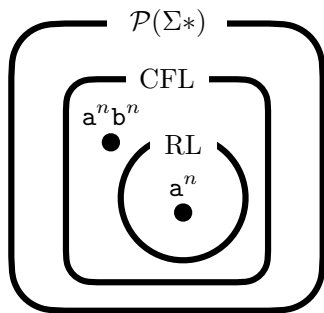

Languages	Automata	Grammars
Context-Free Language (CFL)	Pushdown Automata (PDA)	Context-Free Grammar (CFG)
Regular Language (RL)	Finite Automata (FA)	Regular Expression (RE)

1. Examples of Pushdown Automata

Example 1: $a^n b^n$

Example 2: $a^n b^{2n}$

Example 3: ww^R

Example 4: Balanced Parentheses

Example 5: Equal Number of a's and b's

Example 6: Unequal Number of a's and b's

Example 7: Not of the Form ww

Example 1: $a^n b^n$

Construct a PDA that accepts the language by **final states**:

$$L_F(P) = \{a^n b^n \mid n \geq 0\}$$

Example 1: $a^n b^n$

Construct a PDA that accepts the language by **final states**:

$$L_F(P) = \{a^n b^n \mid n \geq 0\}$$

The key idea is to **count** the number of a's using the stack.

Example 1: $a^n b^n$

Construct a PDA that accepts the language by **final states**:

$$L_F(P) = \{a^n b^n \mid n \geq 0\}$$

The key idea is to **count** the number of a's using the stack.

- 1 Start with the stack only having the initial stack alphabet Z .
- 2 Repeatedly **push** X onto the stack for each a .
- 3 Repeatedly **pop** X from the stack for each b .
- 4 Accept when the top of the stack is Z .

Example 1: $a^n b^n$

Construct a PDA that accepts the language by **final states**:

$$L_F(P) = \{a^n b^n \mid n \geq 0\}$$

$a [Z \rightarrow XZ]$

$a [X \rightarrow XX]$

$b [X \rightarrow \epsilon]$

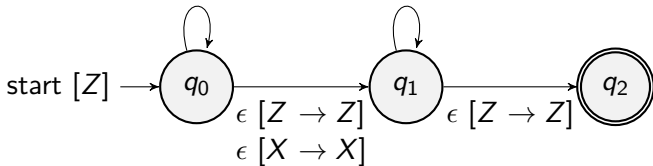

<https://plrg.korea.ac.kr/courses/cose215/materials/pda-an-bn-final.pdf>

Example 2: $a^n b^{2n}$

Construct a PDA that accepts the language by **final states**:

$$L_F(P) = \{a^n b^{2n} \mid n \geq 0\}$$

Example 2: $a^n b^{2n}$

Construct a PDA that accepts the language by **final states**:

$$L_F(P) = \{a^n b^{2n} \mid n \geq 0\}$$

Now, we need to push **two** X 's for each a .

Example 2: $a^n b^{2n}$

Construct a PDA that accepts the language by **final states**:

$$L_F(P) = \{a^n b^{2n} \mid n \geq 0\}$$

Now, we need to push **two** X 's for each a .

- 1 Start with the stack only having the initial stack alphabet Z .
- 2 Repeatedly **push two** X 's onto the stack for each a .
- 3 Repeatedly **pop** X from the stack for each b .
- 4 Accept when the top of the stack is Z .

Example 2: $a^n b^{2n}$

Construct a PDA that accepts the language by **final states**:

$$L_F(P) = \{a^n b^{2n} \mid n \geq 0\}$$

$a [Z \rightarrow XXZ]$

$a [X \rightarrow XXX] \quad b [X \rightarrow \epsilon]$

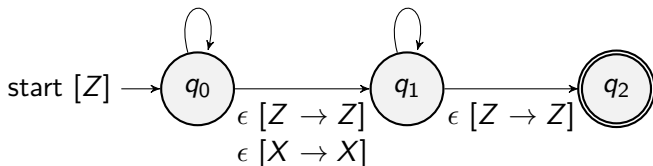

<https://plrg.korea.ac.kr/courses/cose215/materials/pda-an-b2n-final.pdf>

Example 3: ww^R

Construct a PDA that accepts the language by **final states**:

$$L_F(P) = \{ww^R \mid w \in \{a, b\}^*\}$$

Example 3: ww^R

Construct a PDA that accepts the language by **final states**:

$$L_F(P) = \{ww^R \mid w \in \{a, b\}^*\}$$

The key idea is to **store** the first half of the word and **compare** it with the second half in reverse order using the stack.

Example 3: ww^R

Construct a PDA that accepts the language by **final states**:

$$L_F(P) = \{ww^R \mid w \in \{a, b\}^*\}$$

The key idea is to **store** the first half of the word and **compare** it with the second half in reverse order using the stack.

- 1 Start with the stack only having the initial stack alphabet Z .
- 2 Repeatedly **push** X (or Y) onto the stack for each a (or b).
- 3 Repeatedly **pop** X (or Y) from the stack for each a (or b).
- 4 Accept when the top of the stack is Z .

Example 3: ww^R

Construct a PDA that accepts the language by **final states**:

$$L_F(P) = \{ww^R \mid w \in \{a, b\}^*\}$$

$a [Z \rightarrow XZ]$

$a [X \rightarrow XX]$

$a [Y \rightarrow XY]$

$b [Z \rightarrow YZ]$

$b [X \rightarrow YX]$

$b [Y \rightarrow YY]$

$a [X \rightarrow \epsilon]$

$b [Y \rightarrow \epsilon]$

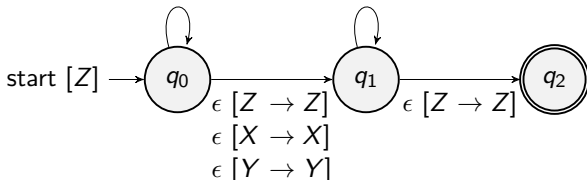

<https://plrg.korea.ac.kr/courses/cose215/materials/pda-w-wr-final.pdf>

Example 4: Balanced Parentheses

Construct a PDA that accepts the language by **empty stacks**:

$$L_E(P) = \{w \in \{(,)\}^* \mid w \text{ is balanced}\}$$

Example 4: Balanced Parentheses

Construct a PDA that accepts the language by **empty stacks**:

$$L_E(P) = \{w \in \{(,)\}^* \mid w \text{ is balanced}\}$$

The key idea is to **count** the number of **unmatched** open parentheses.

Example 4: Balanced Parentheses

Construct a PDA that accepts the language by **empty stacks**:

$$L_E(P) = \{w \in \{(,)\}^* \mid w \text{ is balanced}\}$$

The key idea is to **count** the number of **unmatched** open parentheses.

- 1 Start with the stack only having the initial stack alphabet Z .
- 2 If the current symbol is $($, push $($ onto the stack.
- 3 If the current symbol is $)$, pop $($ from the stack.
- 4 Repeat steps 2 and 3.
- 5 Accept when the top of the stack is Z .

Example 4: Balanced Parentheses

Construct a PDA that accepts the language by **empty stacks**:

$$L_E(P) = \{w \in \{ (,) \}^* \mid w \text{ is balanced}\}$$

([Z → (Z]

([(→ ((]

) [(→ ε]

ε [Z → ε]

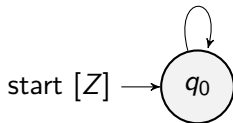

<https://plrg.korea.ac.kr/courses/cose215/materials/pda-balanced-empty.pdf>

Example 5: Equal Number of a's and b's

Construct a PDA that accepts the language by **empty stacks**:

$$L_E(P) = \{w \in \{a, b\}^* \mid N_a(w) = N_b(w)\}$$

where $N_a(w)$ and $N_b(w)$ are the number of a's and b's in w , respectively.

Example 5: Equal Number of a's and b's

Construct a PDA that accepts the language by **empty stacks**:

$$L_E(P) = \{w \in \{a, b\}^* \mid N_a(w) = N_b(w)\}$$

where $N_a(w)$ and $N_b(w)$ are the number of a's and b's in w , respectively.

Consider the following function $f : \{a, b\}^* \rightarrow \mathbb{N}$:

$$f(w) = N_a(w) - N_b(w)$$

Example 5: Equal Number of a's and b's

Construct a PDA that accepts the language by **empty stacks**:

$$L_E(P) = \{w \in \{a, b\}^* \mid N_a(w) = N_b(w)\}$$

where $N_a(w)$ and $N_b(w)$ are the number of a's and b's in w , respectively.

Consider the following function $f : \{a, b\}^* \rightarrow \mathbb{N}$:

$$f(w) = N_a(w) - N_b(w)$$

The key idea is to represent the **positive value** of $f(w)$ using the number of P 's and the **negative value** of $f(w)$ using the number of N 's.

Example 5: Equal Number of a's and b's

Construct a PDA that accepts the language by **empty stacks**:

$$L_E(P) = \{w \in \{a, b\}^* \mid N_a(w) = N_b(w)\}$$

where $N_a(w)$ and $N_b(w)$ are the number of a's and b's in w , respectively.

Consider the following function $f : \{a, b\}^* \rightarrow \mathbb{N}$:

$$f(w) = N_a(w) - N_b(w)$$

The key idea is to represent the **positive value** of $f(w)$ using the number of P 's and the **negative value** of $f(w)$ using the number of N 's.

- 1 Start with the stack only having the initial stack alphabet Z .
- 2 If the current symbol is a, **push** P or **pop** N .
- 3 If the current symbol is b, **push** N or **pop** P .
- 4 Repeat steps 2 and 3.
- 5 Accept when the top of the stack is Z .

Example 5: Equal Number of a's and b's

Construct a PDA that accepts the language by **empty stacks**:

$$L_E(P) = \{w \in \{a, b\}^* \mid N_a(w) = N_b(w)\}$$

where $N_a(w)$ and $N_b(w)$ are the number of a's and b's in w , respectively.

a $[Z \rightarrow PZ]$

a $[P \rightarrow PP]$

a $[N \rightarrow \epsilon]$

b $[Z \rightarrow NZ]$

b $[P \rightarrow \epsilon]$

b $[N \rightarrow NN]$

ϵ $[Z \rightarrow \epsilon]$

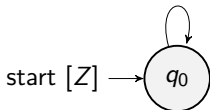

<https://plrg.korea.ac.kr/courses/cose215/materials/pda-eq-a-b-empty.pdf>

Example 6: Unequal Number of a's and b's

Construct a PDA that accepts the language by **empty stacks**:

$$L_E(P) = \{w \in \{a, b\}^* \mid N_a(w) \neq N_b(w)\}$$

where $N_a(w)$ and $N_b(w)$ are the number of a's and b's in w , respectively.

Example 6: Unequal Number of a's and b's

Construct a PDA that accepts the language by **empty stacks**:

$$L_E(P) = \{w \in \{a, b\}^* \mid N_a(w) \neq N_b(w)\}$$

where $N_a(w)$ and $N_b(w)$ are the number of a's and b's in w , respectively.

The key idea is same but we accept the top of the stack is P or N .

Example 6: Unequal Number of a's and b's

Construct a PDA that accepts the language by **empty stacks**:

$$L_E(P) = \{w \in \{a, b\}^* \mid N_a(w) \neq N_b(w)\}$$

where $N_a(w)$ and $N_b(w)$ are the number of a's and b's in w , respectively.

The key idea is same but we accept the top of the stack is P or N .

- 1 Start with the stack only having the initial stack alphabet Z .
- 2 If the current symbol is a, **push** P or **pop** N .
- 3 If the current symbol is b, **push** N or **pop** P .
- 4 Repeat steps 2 and 3.
- 5 Accept when the top of the stack is P or N .

Example 6: Unequal Number of a's and b's

Construct a PDA that accepts the language by **empty stacks**:

$$L_E(P) = \{w \in \{a, b\}^* \mid N_a(w) \neq N_b(w)\}$$

where $N_a(w)$ and $N_b(w)$ are the number of a's and b's in w , respectively.

a	$[Z \rightarrow PZ]$	
a	$[P \rightarrow PP]$	
a	$[N \rightarrow \epsilon]$	
b	$[Z \rightarrow NZ]$	$\epsilon [Z \rightarrow \epsilon]$
b	$[P \rightarrow \epsilon]$	$\epsilon [P \rightarrow \epsilon]$
b	$[N \rightarrow NN]$	$\epsilon [N \rightarrow \epsilon]$

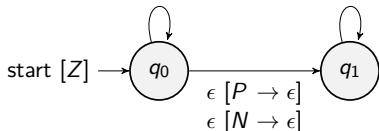

<https://plrg.korea.ac.kr/courses/cose215/materials/pda-uneq-a-b-empty.pdf>

Example 7: Not of the Form ww

Construct a PDA that accepts the language by **empty stacks**:

$$L_E(P) = \{x \in \{a, b\}^* \mid x \text{ is not of the form } ww\}$$

Example 7: Not of the Form ww

Construct a PDA that accepts the language by **empty stacks**:

$$L_E(P) = \{x \in \{a, b\}^* \mid x \text{ is not of the form } ww\}$$

There are two cases of $x \in L_E(P)$:

- 1 x is an **odd-length** word or
- 2 x is divided into two **same-length** but **unequal** words.

Example 7: Not of the Form ww

Construct a PDA that accepts the language by **empty stacks**:

$$L_E(P) = \{x \in \{a, b\}^* \mid x \text{ is not of the form } ww\}$$

There are two cases of $x \in L_E(P)$:

- 1 x is an **odd-length** word or
- 2 x is divided into two **same-length** but **unequal** words.

In the second case, assume $x = a_1 \cdots a_{2n}$. Then,

$$\exists 1 \leq i \leq n. a_i \neq a_{i+n}$$

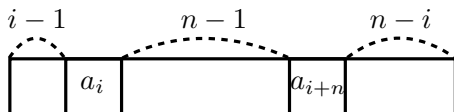

Example 7: Not of the Form ww

Construct a PDA that accepts the language by **empty stacks**:

$$L_E(P) = \{x \in \{a, b\}^* \mid x \text{ is not of the form } ww\}$$

There are two cases of $x \in L_E(P)$:

- ① x is an **odd-length** word or
- ② x is divided into two **same-length** but **unequal** words.

In the second case, assume $x = a_1 \cdots a_{2n}$. Then,

$$\exists 1 \leq i \leq n. a_i \neq a_{i+n}$$

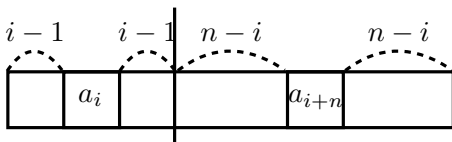

Example 7: Not of the Form ww

Construct a PDA that accepts the language by **empty stacks**:

$$L_E(P) = \{x \in \{a, b\}^* \mid x \text{ is not of the form } ww\}$$

There are two cases of $x \in L_E(P)$:

- ① x is an **odd-length** word or
- ② x is divided into two **same-length** but **unequal** words.

In the second case, assume $x = a_1 \cdots a_{2n}$. Then,

$$\exists 1 \leq i \leq n. a_i \neq a_{i+n}$$

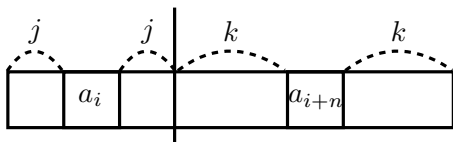

Example 7: Not of the Form ww

Construct a PDA that accepts the language by **empty stacks**:

$$L_E(P) = \{x \in \{a, b\}^* \mid x \text{ is not of the form } ww\}$$

There are two cases of $x \in L_E(P)$:

- ① x is an **odd-length** word or
- ② x is divided into two **odd-length** words whose **centers** are different.

In the second case, assume $x = a_1 \cdots a_{2n}$. Then,

$$\exists 1 \leq i \leq n. a_i \neq a_{i+n}$$

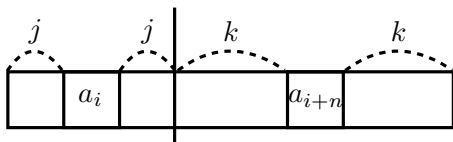

Example 7: Not of the Form ww

Construct a PDA that accepts the language by **empty stacks**:

$$L_E(P) = \{x \in \{a, b\}^* \mid x \text{ is not of the form } ww\}$$

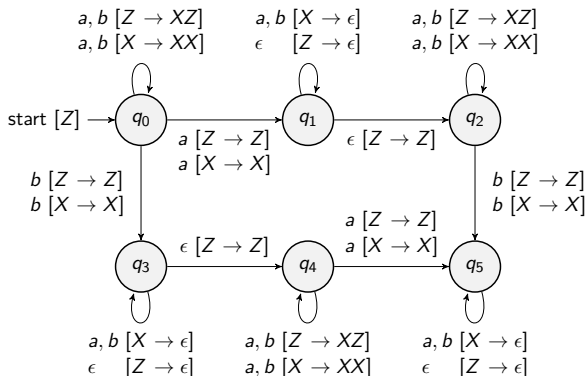

<https://plrg.korea.ac.kr/courses/cose215/materials/pda-not-w-w-empty.pdf>

1. Examples of Pushdown Automata

Example 1: $a^n b^n$

Example 2: $a^n b^{2n}$

Example 3: ww^R

Example 4: Balanced Parentheses

Example 5: Equal Number of a's and b's

Example 6: Unequal Number of a's and b's

Example 7: Not of the Form ww

- Equivalence of Pushdown Automata and Context-Free Grammars

Jihyeok Park

jihyeok_park@korea.ac.kr

<https://plrg.korea.ac.kr>